

# Instrument Double Block & Bleed Range

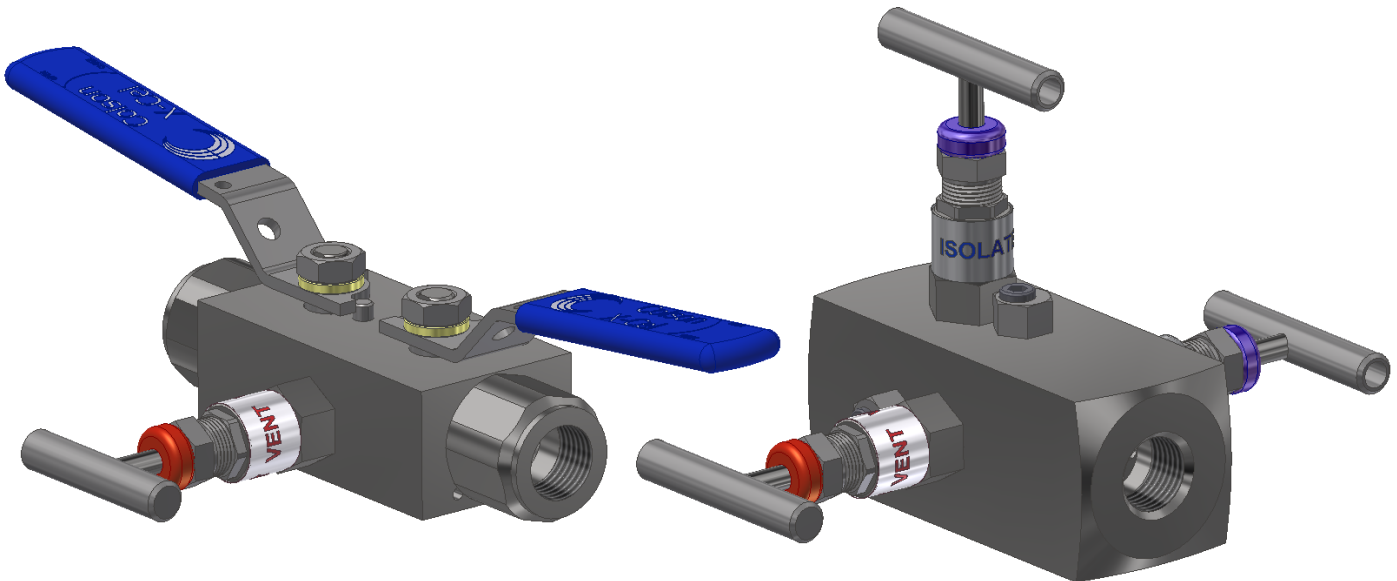

**DBB Series**

**DBN Series**

Colson X-Cel Ltd have extensive knowledge and experience in small bore Double Block and Bleed (DBB) valve technology. The “DBB” and “DBN” range of instrument Double Block and Bleed valves have an extensive reference list in a multitude of applications having served in the oil and gas industry for over 25 years. Colson X-Cel Ltd design, machine, assemble, test and quality assure all products in-house at the Advanced Manufacturing Park in the UK.

The instrument DBB range is a quality engineered, high pressure, Double Block and Bleed valve rated to 10,000 psi.

The DBB valve configuration of a ball, needle, ball, comprises of two soft seated precision ball valves as the primary and secondary isolate and a metal to metal seated needle valve vent. The range is manufactured in bar stock materials certified to NACE with internally loaded, anti-blow out stems and a heavy-duty screwed needle valve vent. Available in sizes from 1/4” to 1/2” with a screwed NPT thread\* as standard.

The DBN valve configuration of a needle, needle, needle comprises of two metal to metal seated isolates and a metal to metal seated needle valve vent. The range is manufactured in bar stock materials certified to NACE with a heavy-duty screwed bonnet for the isolates and vent. Available in sizes from 1/4” to 1/2” with a screwed NPT thread\* as standard.

#### TECHNICAL DATA

##### Materials:

316 Stainless Steel—A479 UNS S31600  
(NACE)

##### Inlet Connection:

1/2” NPT Female (As Std)

##### Outlet Connection:

1/2” NPT Female (As Std)

##### Pressure Rating:

10,000psi (As Std)

##### Operating Temperature Range:

-46°C to 538°C (-51°F to 1000°F)

##### Bore Sizes:

5mm & 10mm

#### DESIGN FEATURES

High Pressure design rated to 10,000psi

Designed to MSS-SP-99

Tested to API 598—Leakage Rate A

Full material traceability

Female NPT connections (1/4” - 1/2”)

Low operating torque

Internally loaded blowout proof stem

Lockable & Actuator options available\*

Other connection types available\*

Exotic materials available\*

Additional sizes available on request\*

Additional threads available on request\*

\*Contact Sales Department

Colson X-Cel Ltd  
R-evolution @ the AMP  
Unit 3 Brindley Way  
Rotherham  
S60 5FS

Phone: +44 (0) 114 243 2898

\*E-mail: sales@colson.co.uk

# Ball/Needle/Ball — DBB Series

## DBB Series — Ball/Needle/Ball

The 10mm bore DBB series valves are supplied with a straight through, fully roddable bore. A low operating torque is achieved using super finished balls and fully supported, cantilever PEEK seats. The needle valve allows a variety of venting options through a low torque tee-bar handle leading to a high integrity NPT connection. The body is sealed using Firesafe Graphite sealing as standard, providing leak tight sealing capability across a wide range of pressures, temperatures and process media.

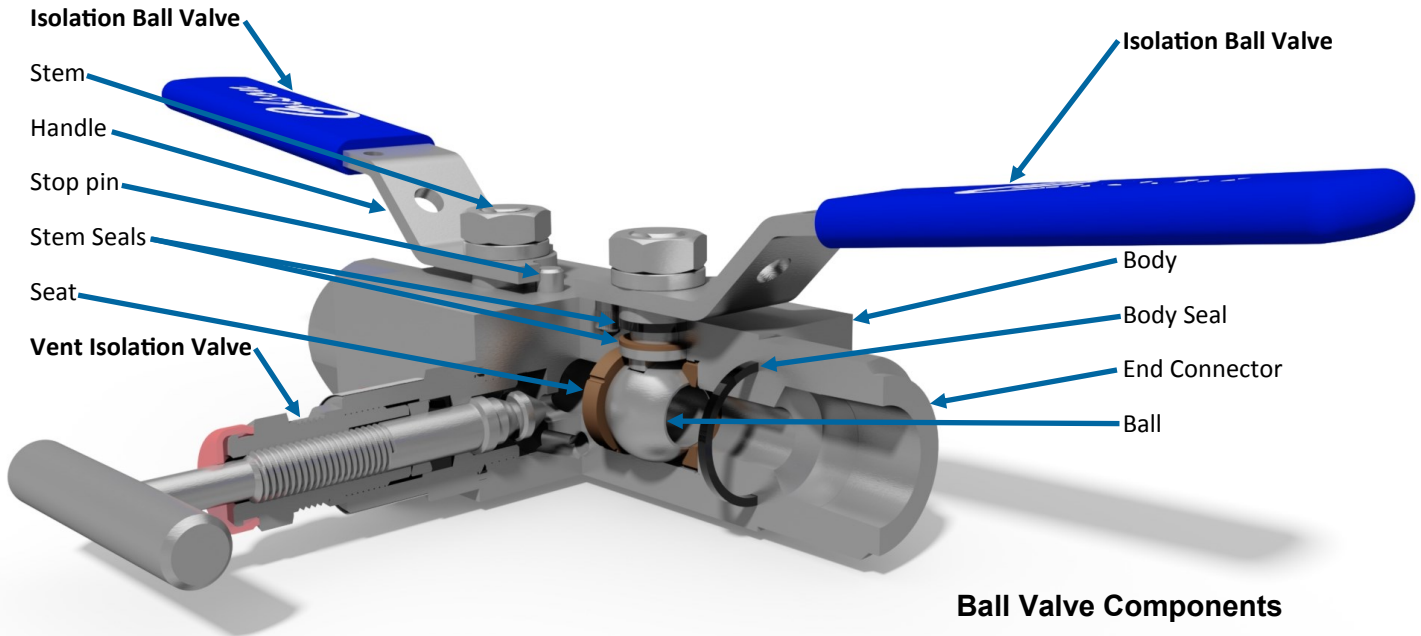

**Ball Valve Components  
Body & Trim Materials**

Description	Material
Body	A479 - UNS S31600
Handle	UNS S31600
Stop pin	UNS S31600
Stem Seal	PTFE/PEEK/Graphite
Handle Sleeve	PVC
Spacer	UNS S31600
Nut	A4 St/Steel
Spring Washer	UNS S31600
Seat	PEEK - 450G
Ball	A479 - UNS S31600
Spindle	A479 - UNS S31600
End Connector	A479 - UNS S31600
Bonnet	A479 - UNS S31600
Thrust Washer	PEEK - 450G
Body Seal	PTFE/Graphite

### APPLICATIONS

- Wellhead Control Panels
- Gauge Isolation
- Chemical Injection Skids
- Lube Oil Systems
- Methanol Injection Packages
- Chemical Distribution Panels
- Waste Water Treatment Systems
- Oil, Water and Sand Separation Systems
- Produced Water Treatment Packages
- Pump Packages

Colson X-Cel Ltd  
R-evolution @ the AMP  
Unit 3 Brindley Way  
Rotherham  
S60 5FS

Phone: +44 (0) 114 243 2898  
\*E-mail: sales@colson.co.uk

# Needle/Needle/Needle — DBN Series

## DBN Series - Needle/Needle/Needle

The 5mm bore DBN(X) series valves are supplied with a compact bar stock body. The needle valves allow easy operation using a low torque tee-bar handle with high integrity NPT connections. The body is sealed using Firesafe Graphite along with metal to metal sealing as standard providing leak tight sealing capability up to 10,000psi working pressure and a rated temperature of up to 400°C\*.

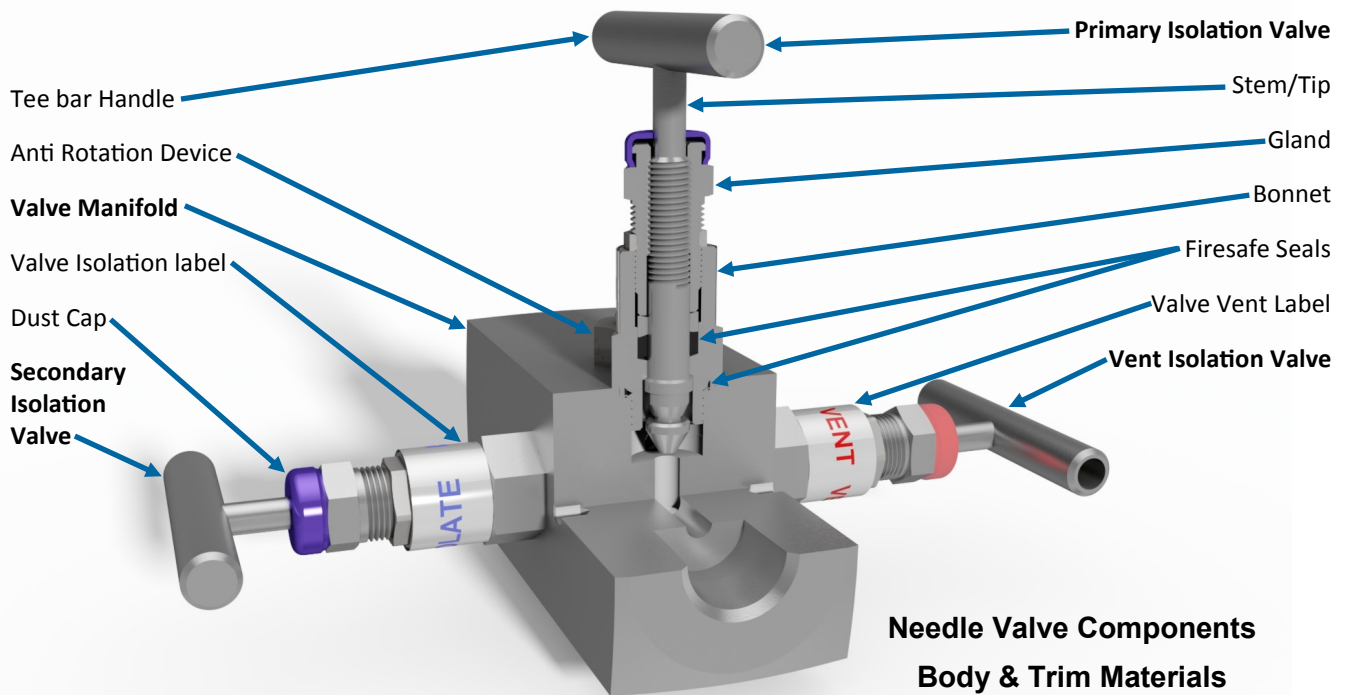

**Needle Valve Components  
Body & Trim Materials**

### APPLICATIONS

- Wellhead Control Panels
- Gauge Isolation
- Chemical Injection Skids
- Lube Oil Systems
- Methanol Injection Packages
- Chemical Distribution Panels
- Waste Water Treatment Systems
- Oil, Water and Sand Separation Systems
- Produced Water Treatment Packages
- Pump Packages

Description	Material
Body	A479 - UNS S31600
Tee Bar Handle	UNS S31600
Dog point screw	UNS S31600
Gland Seal	Graphite
Dust Cap	PVC
Packing Follower	UNS S31600
Stem/Tip	A479 UNS S31600
Tab Washer	UNS S31600
Anti-Rotation Device	UNS S31600
Socket Cap Screw	UNS S31600
Gland Locknut	UNS S31600
Gland	A479 - UNS S31600
Bonnet	A479 - UNS S31600
Body Seal	UNS S31600
Body Seal	Graphite

Colson X-Cel Ltd  
R-evolution @ the AMP  
Unit 3 Brindley Way  
Rotherham  
S60 5FS

Phone: +44 (0) 114 243 2898  
\*E-mail: sales@colson.co.uk

# High Pressure Double Block & Bleed Range

## DBN(X) Weights and Dimensions

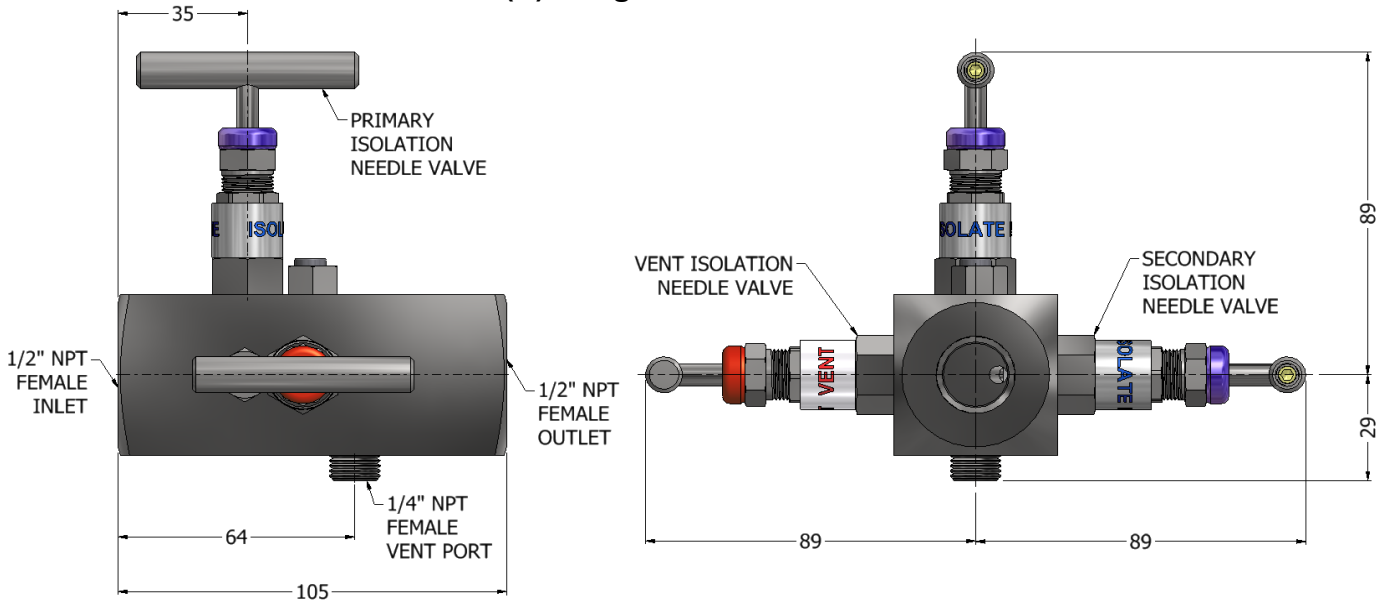

### DBN Range

Part Number	Connection Size	Bore	Face to Face (A)	Body Size	Between centres (B)	Inlet to Centre (C)	Weight	Pressure
DBNCNX0515NF1S-FS	1/2"	5mm	105mm	44.5mm Square	N/A	35	1.9kg	10,000psi

## DBB(X) Weights and Dimensions

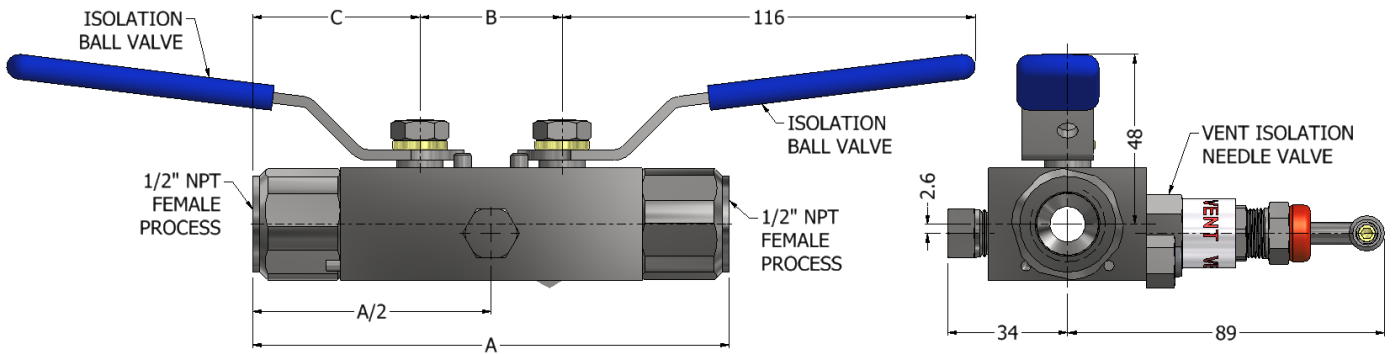

### DB(B/N) Range

Part Number	Connection Size	Bore	Face to Face (A)	Body Size	Between centres (B)	Inlet to Centre (C)	Weight	Pressure
DBBCMP1015NF1S	1/2"	10mm	134mm	44.5mm x 31.8mm	50mm	42mm	1.3kg	6,000psi
DBBCM1015NF1S-FS	1/2"	10mm	134mm	44.5mm x 31.8mm	40mm	47mm	1.3kg	10,000psi

Colson X-Cel Ltd  
R-evolution @ the AMP  
Unit 3 Brindley Way  
Rotherham  
S60 5FS  
Phone: +44 (0) 114 243 2898  
\*E-mail: sales@colson.co.uk

# High Pressure Double Block & Bleed Range

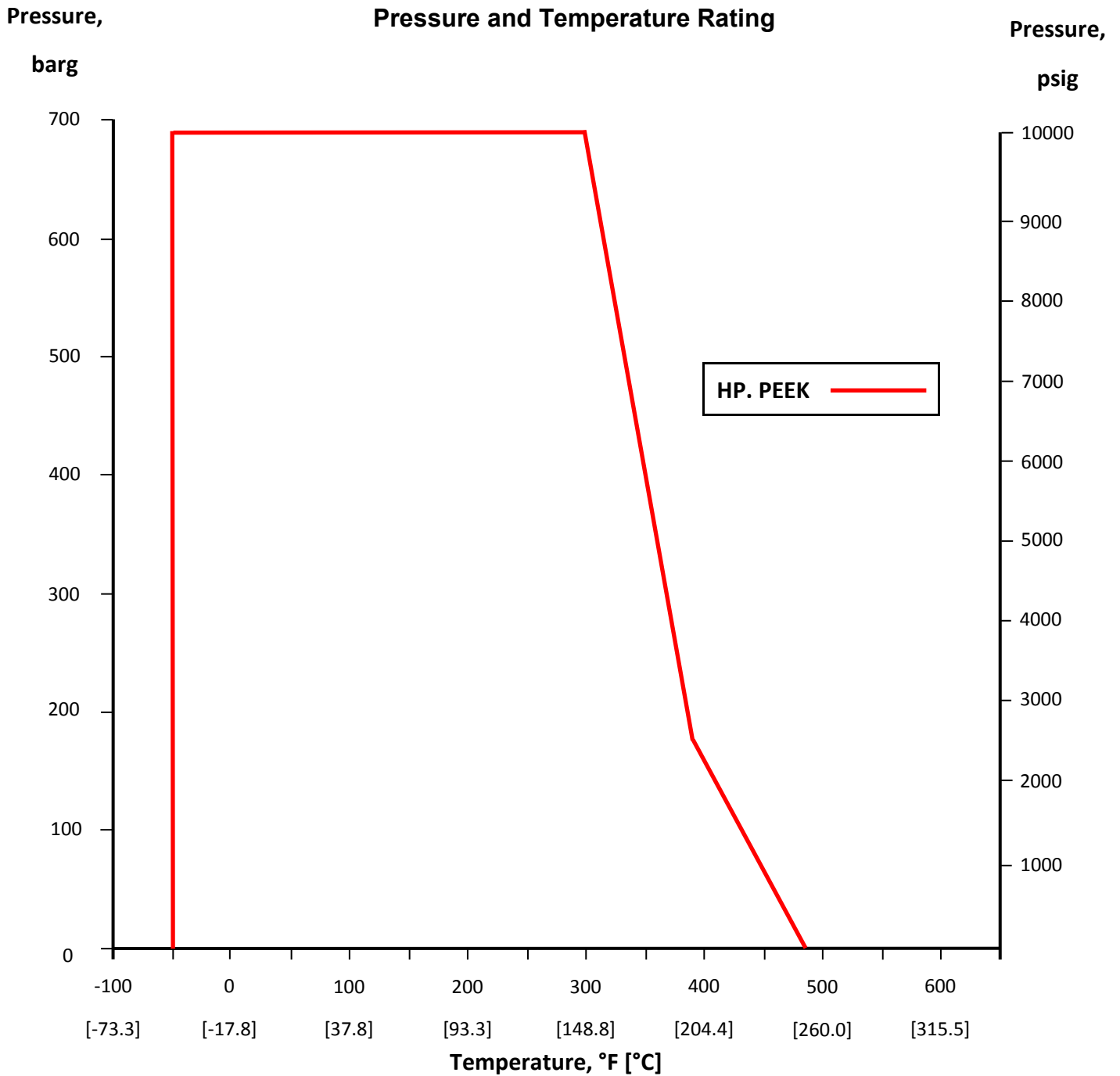

Colson X-Cel Ltd  
 R-evolution @ the AMP  
 Unit 3 Brindley Way  
 Rotherham  
 S60 5FS

Phone: +44 (0) 114 243 2898  
 \*E-mail: sales@colson.co.uk

Note:  
 ASME Class ratings based on ASME B16.5 Table A-2 - Rated Ceiling Pressure (psi)  
 For material specific pressure rating - see relevant tables in ASME B16.5